

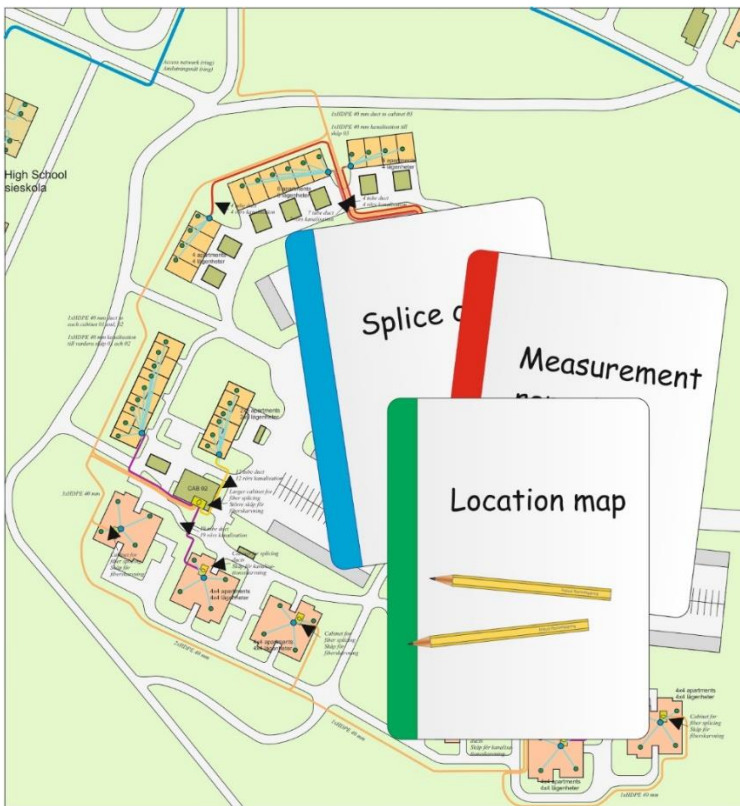

Instructions for Robust Fiber Appendix 5 Documentation

Ver 1.3.1



CONTENTS

1.	Introduction	3
2.	Documentation.....	4
	2.1 General requirements	4
	2.2 Scope	5
	2.3 Requirements regarding documentation that must be included	6
	2.3.1 Network overview.....	6
	2.3.2 Ducting	7
	2.3.3 Fibre optic cables.....	10
	2.3.4 Sites and nodes	15
	2.3.5 Land agreement.....	17
	2.4 Documents that should be included.....	18
	2.4.1 Distribution point drawing	18
	2.4.2 Distribution point card.....	19
	2.4.3 Site drawing	20
	2.4.4 Cross-section drawing for trench.....	20
	2.5 Management of documentation	21

1. INTRODUCTION

The document "*Instructions for Robust Fiber*" comprises one main document and a number of appendices.

This appendix, Documentation, contains minimum requirements for how a robust fibre installation should be documented and which parts should be included in the documentation. The appendix also contains recommendations and examples of the possible appearance.

Minimum requirements within the following areas are defined in the appendix.

- General requirements
- Network overview
- Ducting drawing
- Location map
- Survey files
- List of items
- Ducting drawing on private building land
- Registration
- Cable drawing
- Cable specification
- Splicing plan
- Panel card
- Measurement report
- Rack layout drawing
- Access information
- Land agreement
- Management of the documentation

2. DOCUMENTATION

2.1 General requirements

The documentation must generally contain information that

- describes the complete network,
- facilitates robust operation of the fibre installation.

Furthermore, the documentation must

- be able to be transferred between different editable digital formats,
- contain the information that is required in the event of a transfer of ownership of the fibre installation.

The documentation must be prepared in an editable digital format.

For example, the documentation may be available in a system intended for the documentation of fibre installations. Alternatively, different parts of the documentation may comprise different file formats, such as Excel, Word, etc. Files of the type .pdf must not be used as originals as they are not editable.

The network's constituent parts must have uniform names.

The names of a network's constituent parts may differ between different network owners. Regardless of the names of the various constituent parts in a network, the network owner must nevertheless have uniform designation for them based on their function in the network. The structure and the designations must make it possible for the documentation to be supplemented in the event of any future changes to the network.

MINIMUM REQUIREMENTS, GENERAL

An individual constituent in a fibre installation must be documented so that:

- It cannot be confused with other parts thanks to being allocated a unique designation.
- It can be located on site by means of the geographic location and/or section being clearly set out in the documentation.
- Drawings and pictures clearly describe the structure and format of the fibre installation, as well as how other constituents are connected.
- Properties that are significant for the function of a constituent part in the network are set out.
- There is a description of how the constituent can be accessed in the event of faults as well as during modification, operation and maintenance work.
- Designations and other data are accessible, searchable and can be clearly presented from an operation, maintenance and marketing perspective.

Consequences in the event of any damage must be able to be surveyed and assessed rapidly by means of the documentation specifying or indicating:

- A fibre optic cable's unique designation and its transfer route in the ducting network.
- A fibre link's unique designation, the cable(s) in which it is found and the location of its termination points.
- A connection's unique designation and the fibre links it comprises.
- Which connection(s) constitutes a unique customer connection.
- A customer connection's link to the relevant customer agreement.
- Agreed SLA when the connection is, or is part of, a leased connection, so that a prioritisation list can be drawn up during troubleshooting.

2.2 Scope

MINIMUM REQUIREMENTS, SCOPE

- The documents that are described below must be present as individual constituents or be incorporated in documentation systems.

The following must be included in the documentation:

Network overview	Schematic overview of the network's geographic extent
Ducting drawing	Schematic drawing of ducting (nodes, manholes, cabinets and ducts)
Location map	Shows the geographic extent of the ducting, measured on a digital base map
Survey files	Coordinates for introduction on a Location map
List of items	List of ducting items for survey file
Ducting drawing, building land	Planning drawing and approval of duct routing on private building land
Cable drawing	Schematic drawing that provides an overview of the fibre optic cables and how they are connected
Cable specification	Specification of fibre optic cable
Splicing plan	Detailed drawing that shows fibre optic cables' splices and terminations. Can also be a connection table.
Panel card	List of terminations of fibre optic cables in ODF, as well as their connections.
Measurement report	Measurement report from delivery measurements in the form of attenuation measurements and/or OTDR measurements.
Rack layout drawing	Drawing that shows what is in the rack and in which position it is located
Access information	Information about keys (pass cards, codes, gate locks) contact persons and route description to site or node
Land agreement	Various agreements about the right to route ducts on another party's land. The following documents should

also be included in the documentation:

Distribution point drawing	Schematic drawing of the ducts in a distribution point
Distribution point card	Specification of distribution point
Site drawing	Schematic drawing of site and node area
Cross-section drawing for trench	Schematic drawing showing a cross-section of a trench with buried ducts

2.3 Requirements regarding documentation that must be included

2.3.1 Network overview

MINIMUM REQUIREMENTS, NETWORK OVERVIEW

- A network overview must be drawn up.

The network overview provides a schematic overview of the network's geographic extent and the locations it reaches, as well as how these are connected to each other. The network overview is normally used for marketing purposes in order to describe the extent of the network.



Example of network overview

2.3.2 Ducting

MINIMUM REQUIREMENTS, DUCTING

The documentation must comprise the following documents:

- ducting drawing
- location map
- survey file
- list of items
- ducting drawing, private building land

2.3.2.1 Ducting drawing

MINIMUM REQUIREMENTS, DUCTING DRAWING

- Ducting drawing must be produced.

Ducting drawing is a schematic drawing that shows nodes, manholes and connection cabinets, as well as the ducts that connect them. Sub-ducting must also be shown on the drawing.

In those cases where ducting contains several ducts in the same trench, the identity of each duct must be clear by means of the duct's colour code and/or labelling at either end. Colour codes or labelling of sub-ducts and microducts must also be presented.

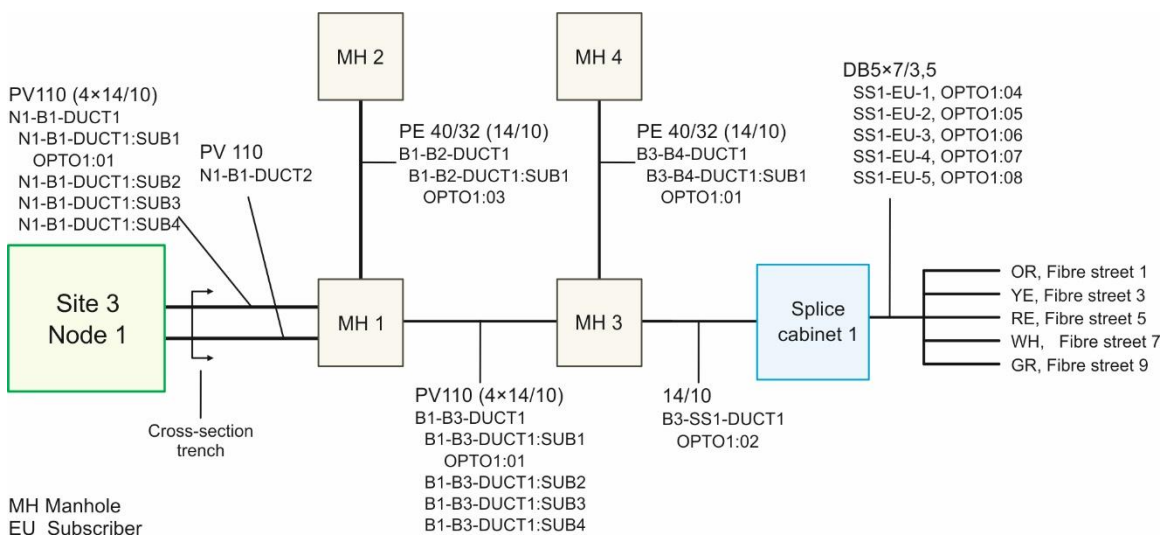

Example of ducting drawing

2.3.2.2 Location map

MINIMUM REQUIREMENTS, LOCATION MAP

- Location map must be produced.

The location map shows the geographic extent of the ducting on a digital base map. The location map is used e.g. during excavation work where cables in the work area need to be identified and indicated.

A survey file containing coordinates and a list of items constitute the basis for the location map.

The coordinate system that is used must be specified (e.g. WGS 84, RT 90 2.5 gon V, SWEREF 99 TM or SWEREF 99 (local zone)).



Example of location map

2.3.2.3 Survey file

Below is an example of a list of measured coordinates that has been created during geodetic position measurement of the ducting. Z indicates the height in metres above sea level (in principle) and can be used to determine the flatness of the ducting's routing.

No.	X	Y	Z
0001	6403406.196	1272605.785	17.916
0002	6403402.562	1272608.213	17.677
0003	6403400.5	1272611.273	17.555
0004	6403399.576	1272614.513	17.717

2.3.2.4 List of items

Example of list of surveyed items

No.	Item	X	Y	Z
0042	C2	6405249.313	1271802.695	30.194
0043	E2	6405249.395	1271802.762	30.05
0044	H2	6405249.461	1271802.589	30.154
0045	C2	6405249.213	1271802.648	30.13

Examples of items:

C2 = Duct

E2 = Switch cabinet

H2 = Cable manhole

MINIMUM REQUIREMENTS IN THE CASE OF SEARCH WIRE

- Where search wire has been used, the documentation must also contain information showing the points at which the search wire is accessible.

2.3.2.5 Ducting drawing, private building land

MINIMUM REQUIREMENTS, DUCTING DRAWING

- Ducting drawing must be produced, with agreed position for cable routing on private building land.

The drawing must show where on the plot the cable connects, where it is to be routed on the plot, and also show where connection to the building takes place. The drawing is created in consultation with the property owner. The drawing should be signed by both client (or contractor) and property owner at the time of planning.

Drawings should also be produced in cases where the property owner is excavating on his own plot. The property owner must have his own specimen or a copy.

See example at the end of the appendix

2.3.2.6 Register fibre installation

MINIMUM REQUIREMENTS, REGISTRATION

- The fibre installation must be registered.

The fibre installations must be registered in accordance with *Appendix 8 Ledningskollen* or in accordance with local procedures and regulations.

2.3.3 Fibre optic cables

MINIMUM REQUIREMENTS, FIBRE OPTIC CABLES

The documentation must comprise the following documents:

- cable drawing
- cable specification
- splicing plan (connection table)
- panel card
- measurement report

2.3.3.1 Cable drawing

MINIMUM REQUIREMENTS, CABLE DRAWING

- A cable drawing must be present.
- It should be stated in which duct a cable is placed.

The cable drawing is a schematic drawing that provides an overview of the fibre optic cables and how they are connected via distribution points and terminations.

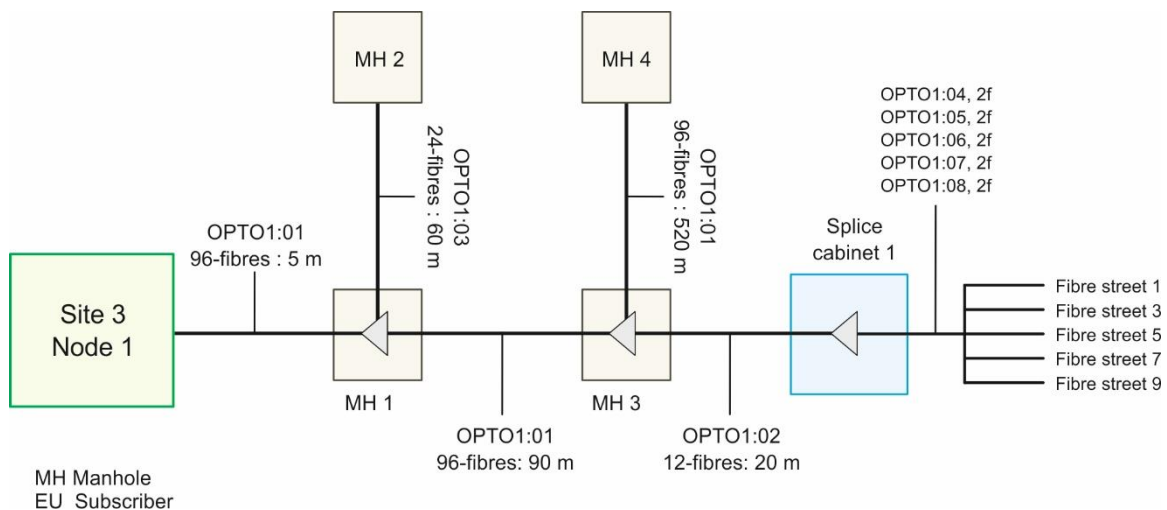

Example, cable drawing

2.3.3.2 Cable specification

MINIMUM REQUIREMENTS, CABLE SPECIFICATION

- A cable specification must be present.

The cable specification is a specification of the individual fibre optic cable, with information about e.g. the cable's designation, the manufacturer's designation, the number of fibres and the length of the fibre optic cable.

Details	Information
Designation	OPTO1
Type of cable according to ITU-T	ITU-T G.652.D
Number of fibres	96
Manufacturer's designation	XYZ 1234-9876-96
Technical specification	See document ABC-0345-96
Carried out by contractor, date	Optodragarna AB, 01/04/2016
Length	684 m
Splicing points and splicing boxes	See document DEF-0678-87
Measurement report	See document GHI-987-654

Example of cable specification

2.3.3.3 Splicing plan

MINIMUM REQUIREMENTS, SPLICING PLAN

- A splicing plan must be drawn up.

The splicing plan is a detailed drawing or a connection table that shows fibre optic cables' splices and terminations.

It must be clear from the splicing plan how individual fibres are spliced in the splicing unit and terminated in ODF.

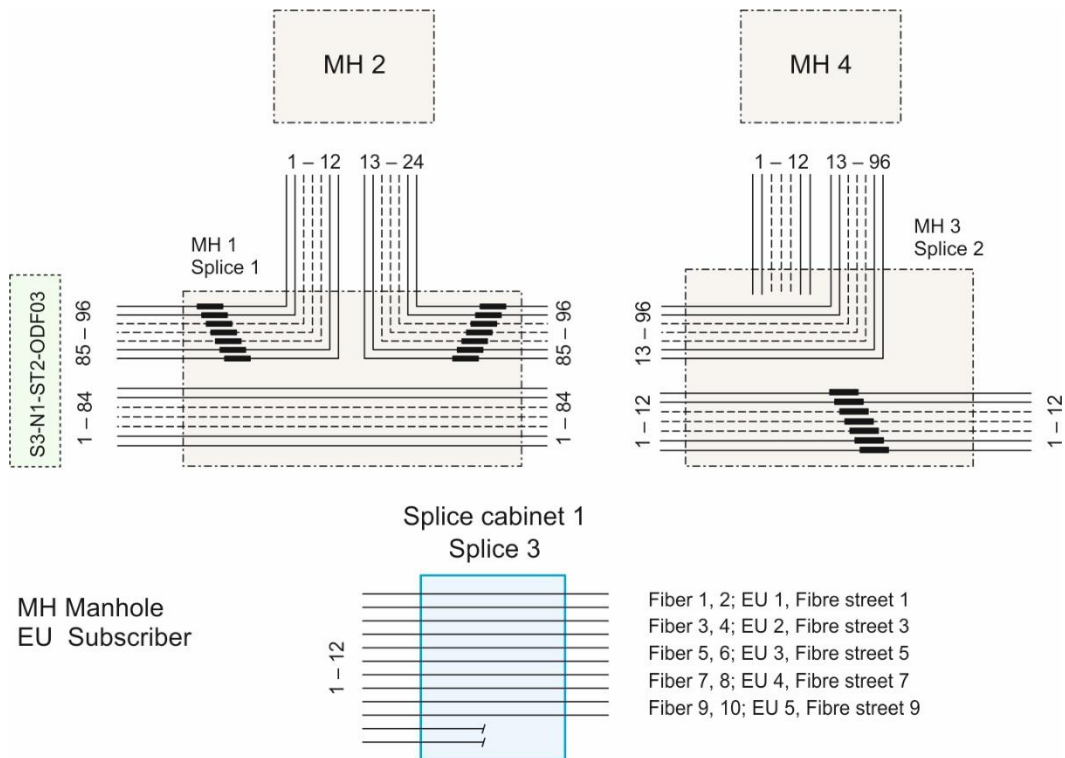

Example, splicing plan

2.3.3.4 Panel card

MINIMUM REQUIREMENTS, PANEL CARD

- A panel card must be produced.

A panel card is a list of terminations in an ODF.

The panel card must contain information about the position of fibres in ODF rack and ODF panel, as well as information about where the other end of the fibre optic cable is terminated. It must also contain information about where a connection cable in a particular position is connected, as well as information about the connection.

Kontakt	Typ	Till	Förbindning	Armräkningar	Kontakt	Typ	Till	Förbindning	Armräkningar
01	SC	Fibervägen 1	SS-N1-ST3-Switch05.01	Villakund 1	25	SC	96		
02	SC	Fibervägen 1			26	SC	96		
03	SC	Fibervägen 3	SS-N1-ST3-Switch05.02	Villakund 2	27	SC	96		
04	SC	Fibervägen 3			28	SC	96		
05	SC	Fibervägen 5	SS-N1-ST3-Switch05.03	Villakund 3	29	SC	96		
06	SC	Fibervägen 5			30	SC	96		
07	SC	Fibervägen 7	SS-N1-ST3-Switch05.04	Villakund 4	31	SC	96		
08	SC	Fibervägen 7			32	SC	96		
09	SC	Fibervägen 9	SS-N1-ST3-Switch05.05	Villakund 5	33	SC	96		
10	SC	Fibervägen 9			34	SC	96		
11	SC				35	SC	96		
12	SC				36	SC	96		
13	SC				37	SC	96		
14	SC				38	SC	96		
15	SC				39	SC	96		
16	SC				40	SC	96		
17	SC				41	SC	96		
18	SC				42	SC	96		
19	SC				43	SC	96		
20	SC				44	SC	96		
21	SC				45	SC	96		
22	SC				46	SC	96		
23	SC				47	SC	96		
24	SC				48	SC	96		
Armr.									
Armr.									
Kabel OPTO1									
Ritad, konstruerad av Kalle Karlsson					Granskad av Bo Bosson				
Datum och underskrift 2016-04-01					Arbetsnummer 654321				
					Andringsdatum				
					Stativ ST2				
					Panel 11A				
					ODF 03				
PANELKORT									

Example, panel card

2.3.3.5 Measurement report

MINIMUM REQUIREMENTS, MEASUREMENT REPORT

- Measurement reports from delivery measurements in the form of OTDR measurements must be included in the documentation.
- Used measuring instruments must be specified in the measurement report. Software for reading the measurement results must be included in the documentation.

See Robust Fiber's instructions, appendix 2, points 2.5.11–13 for minimum requirements during measurement.

The measurement report is ideally attached to the cable specification. The format of the measurement record can be PDF.

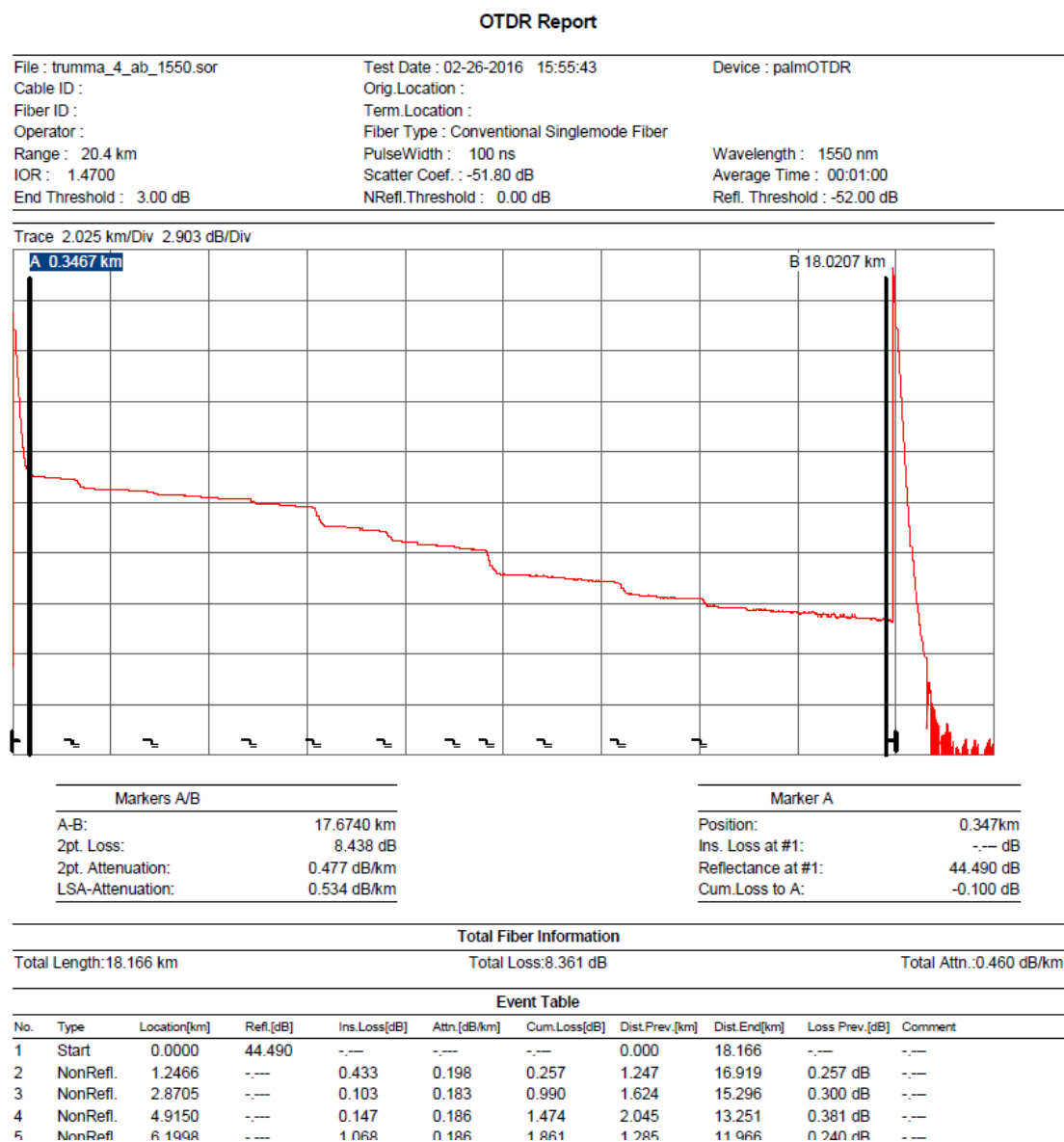

Example, measurement report, OTDR measurement

2.3.4 Sites and nodes

2.3.4.1 Rack layout drawing

MINIMUM REQUIREMENTS, RACK LAYOUT DRAWING

- There must be a rack layout drawing.

ST2		Position	Typ	Kabel
01A	ODF01	01A	ODF 96xSC	OPT05
	ODF02	01C	ODF 96xSC	OPT09
11A	ODF03	11A	ODF 96xSC	OPT01
	ODF04	11C	ODF 48xSC	OPT04
21A				
31A				
41A				
51A				
61A				
71A				
81A				
91A				

2.3.4.2 Access information

MINIMUM REQUIREMENTS FOR ACCESS INFORMATION

- Access information must be present.

The access information is a document that shows the route to a site or node (route description), where keys (pass cards, codes, gate locks) are located and which keys are required, as well as who is the responsible contact person for the site or node. Particularly important in the event of placement at another property owner.

Example, access information:

Access information

Network owner		
Site designation		
Node designation		
Street address		
Town		
Coordinates X and Y	X:	Y:
Created by		
Approved by		
Date		
Directions		
Key information		
Property manager		
Contact person property		
Electricity grid owner		
Contact, electricity grid		
Location of equipment		
Location of demarcation point		
Other information		
Space for image		

2.3.5 Land agreement

MINIMUM REQUIREMENTS, LAND AGREEMENT

- Required land agreements must be drawn up and stored together with the documentation.

Agreements regarding access to land are available in several different variants and with different purposes.

There must be a general land agreement as a basis, which has been entered into between the network owner and the local authority where the fibre installation is to be built. A general land agreement regulates the right to have cables in municipal land, regulations for restoration, any costs for future maintenance, etc.

Below are examples of various types of agreements:

Land lease agreement

- Agreement where the land owner grants e.g. the cable owner the right to use the land for laying cables. Binding for a maximum of 25 years (in planned ground) or 50 years (other ground). One agreement is entered into per property.

Utility easements

- The strongest form of agreement for cables. Regulates the right for legal entities to route cables through the property of other parties. A cadastral survey must be performed and utility easements apply until further notice and are presented on the property register map. Utility easements can relate to several properties.

Usufruct agreement

- Agreement that regulates the right to use something that is owned by another party. An example of this is the hiring of ducts.

Easement

- Can e.g. regulate the right to use another party's land for roads up to the site.

Other agreements and terms

- For example, agreements regarding terms and conditions for collocation, agreements regarding cable location with land owner.

Agreement templates can be obtained from the Federation of Swedish Farmers, the Swedish Broadband Forum, Byanätsforum, etc.

2.4 Documents that should be included

The following documents are not mandatory but should be included. If the documents are included in the documentation, the minimum requirements must be met.

2.4.1 Distribution point drawing

When several ducts terminate in or pass a manhole or a switch cabinet, the documentation should be supplemented with a distribution point drawing. This should give a schematic presentation of the distribution point with ducts.

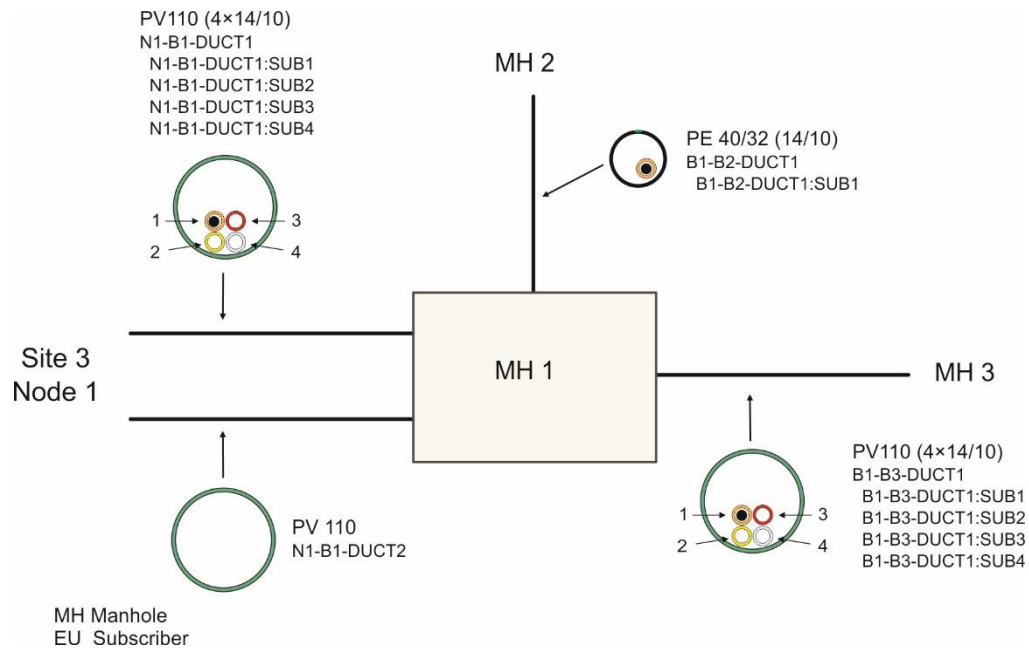

Example of distribution point drawing

2.4.2 Distribution point card

A distribution point card is a specification showing information about the distribution point. Distribution point cards should be produced and can contain all the information or refer to other documents.

Examples:

Details	Information
Distribution point designation	Manhole 1
Type of distribution	Manhole level with the ground surface
Manufacturer's type designation	ABC-3456-78
Material	Concrete with cast iron cover
Interior dimensions in mm: width, depth and height	1200 x 800 x 600
Type of shell protection	Cast iron cover at ground level, inner hatch with lock
Layout drawing	Document ABC-12324-09
Accuracy class during survey	Accuracy class 2
Assignment agreement, rental agreement or similar	Land agreement ABD-12345

Example of distribution point card

2.4.3 Site drawing

The site drawing is a schematic drawing that should be produced and that presents the internal space in a site. The drawing must present designations and the nodes, racks and other units found in the site, as well as where they are located.

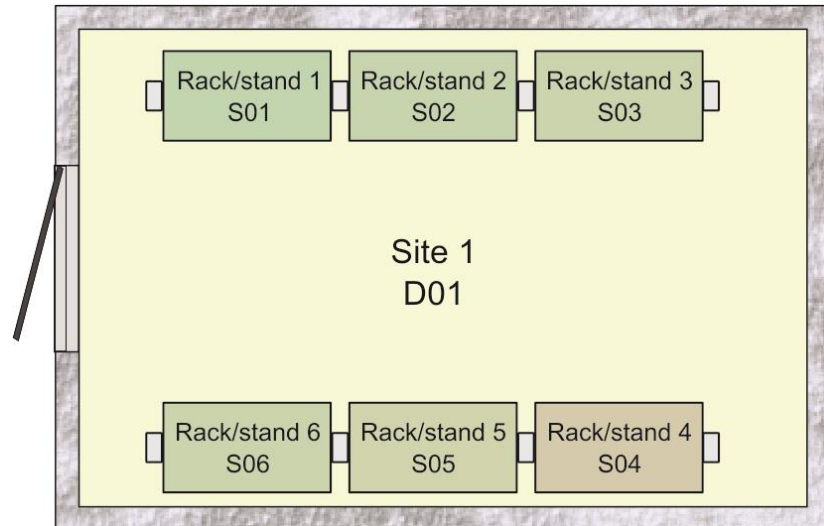

Example, site drawing

2.4.4 Cross-section drawing for trench

The drawing is a schematic drawing that shows a cross-section of buried ducts and their designation, including sub-ducts.

The drawing must set out relevant ducts, their designations and mutual location in the trench. The direction of the cross-section must also be specified.

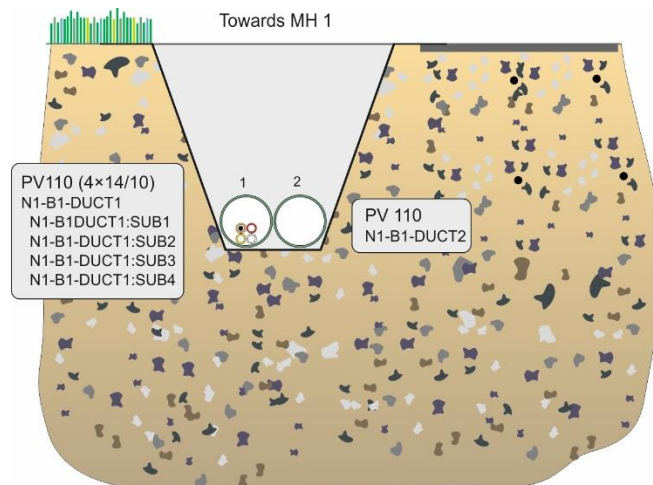

Example, cross-section drawing for trench

2.5 Management of documentation

The documentation must be viewed and handled as sensitive information, as it describes the network's extent, structure and geographic location. The documentation may therefore only be passed to outside parties in accordance with settled regulations.

Minimum requirements for management:

- There must be an appointed function that continually updates the documentation in the event of changes in the fibre installation
- The electronic version of the documentation must be stored in such a way that the risk of it being lost is minimised. It is recommended to have backups in at least two different physical locations.
- The documentation must be stored in such a way that it is accessible in the event of actual or anticipated fault situations, so that faults can be rectified quickly.

Ducting drawing with approval

Network owner		Date	
Area		Company	
Street address		Town	
Fixed designation		Filled in by	

Checklist	OK	
Location of transfer point in relation to street agreed		
Marking for transfer point in relation to street located		
If the number of excavated metres exceeds that which is included, customer notified about additional costs		
Customer notified that only rough restoration is performed on building land		
Location of intake point in the property agreed		
Marking for intake point in the property located		
Customer notified that cable protection chute is placed on facade		
Customer notified that 5 metre internal installation is included		
Transfer route for internal installation agreed		
Location of installation of fibre termination agreed		
Location of placement of media converter agreed		
Other:		
Information	Ye s	No
Is there existing ducting between plot boundary and property?		
Is there a cellar?		
Is there a crawl space? (leave note about access under "Other")		
Does the customer approve work on the building plot being carried out when the customer is not at home?		

Other information

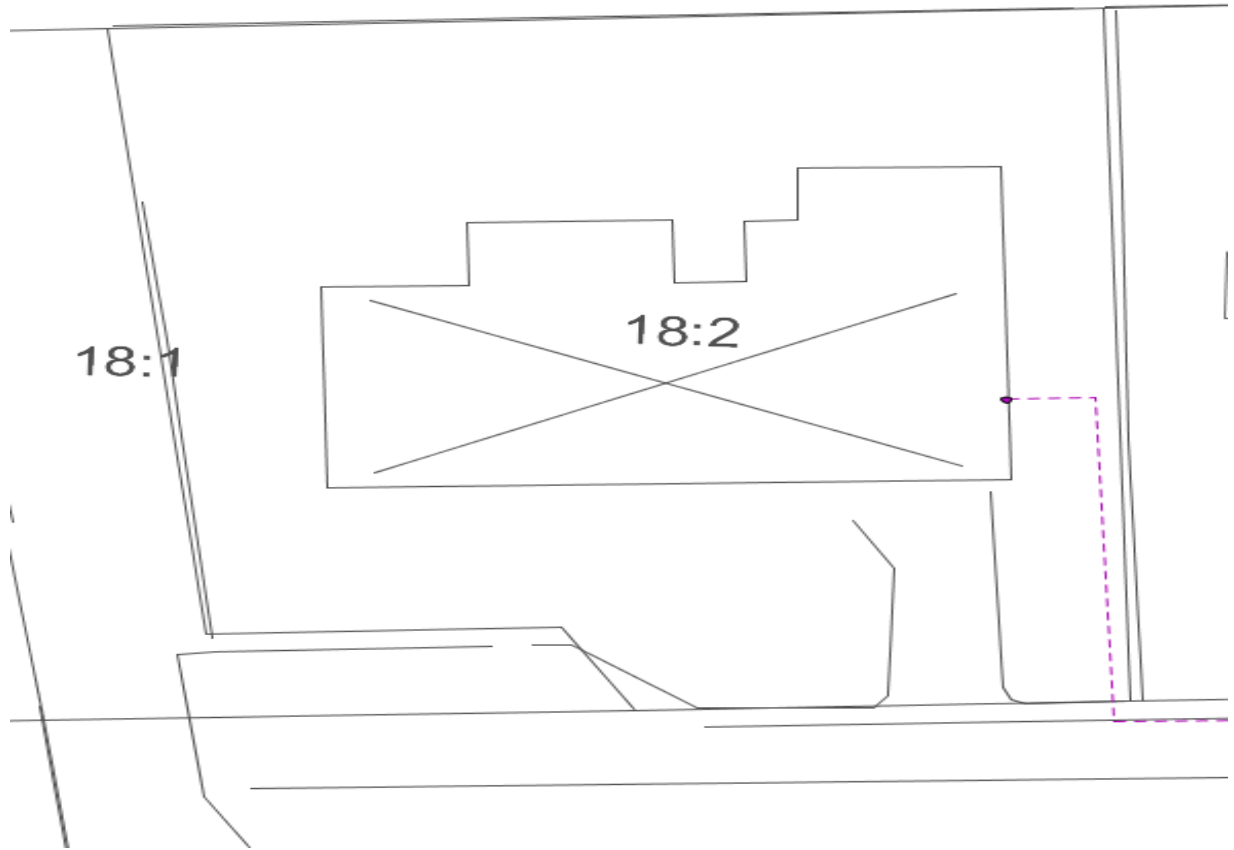

Plot sketch

Approval

Information provided in this form is hereby approved

Property owner 1

Property owner 2

Clarification

Clarification

Planner

Clarification